

1.6 Release History

Major milestones in the product release, see Table 1-1:

Table 1-1. MVI-MODBUS Release History

Version	Description
1.0	Initial Release for Advant Controller 100 Series.

1.7 Terminology

AC 100 is an abbreviation for the ABB Master Advant Controller 100 Series (Advant Controller 110).

AC 110 is an abbreviation for the ABB Master Advant Controller 110.

AMPL (ABB Master Program Language) is a function-block language with graphic presentation which is especially oriented towards process control. The AMPL is used for configuration and application building in the ABB Master controllers.

Controller refers to the ABB Master Controllers.

DAT is a concept in the data base that holds a data value (one Real (4 bytes), one Integer (2 or 4 bytes) or 32 Boolean values). The data values to DS and MS are held by connected DAT elements. *Note: MVI-MODBUS only supports DAT elements with 2 byte Integers or 32 Boolean values for the MVB (see below).*

MVB is the DB element used for the actual data transfer.

MVI is an abbreviation for the ABB Master MultiVendor Interface.

PC program (Process Control program) is a program written in AMPL.

PLC is an abbreviation for Programmable Logic Controller (for example, Gould Modicon 484 Controller).

Poll messages (idle traffic) are sent from an MVI-MODBUS master node to the slave nodes when nothing else is transferred on the MVI-MODBUS link (cycle time can be configured). The poll messages are necessary for supervision of the link status. The MODBUS Function code 8 (Diagnostic loop-back) is used as a poll message.

A number of different names are used for values handled in the MODBUS protocol. This is a short description of the different names and their meanings:

Table 1-2. Names used in MODBUS and in AC 110

MODBUS	AC 110
Coil status	Digital output - one Boolean in a DAT(B)
Output status	Digital output - one Boolean in a DAT(B)
Input status	Digital input - one Boolean in a DAT(B)
Holding registers	Analog output - one Integer DAT(I)
Output registers	Analog output - one Integer DAT(I)
Input register	Analog input - one Integer DAT(I)
Single coil	Digital output - one Boolean in a DAT(B)
Multiple coils	Digital outputs - multiple Booleans in a DAT(B)
Multiple registers	Analog outputs - multiple Integer DAT(I)s

1.8 Product Overview

MVI-MODBUS in the AC 110 provides communication capabilities using multidrop or point to point. Traffic on a MVI-MODBUS link is controlled by a master station. Direct communication is possible only between the master and the slaves. MVI-MODBUS in AC 110 consists of three parts:

- The **PC program** (Process Control program), written in AMPL, is used to define and control the data flow on the link.
- The ABB Master process **data base** is used to configure the communication submodule, CI532V02, and to store the data.
- The **CI532V02** communication submodule runs the MVI-MODBUS protocol in the Advant Controller 110.

Advant Controller 100 Series

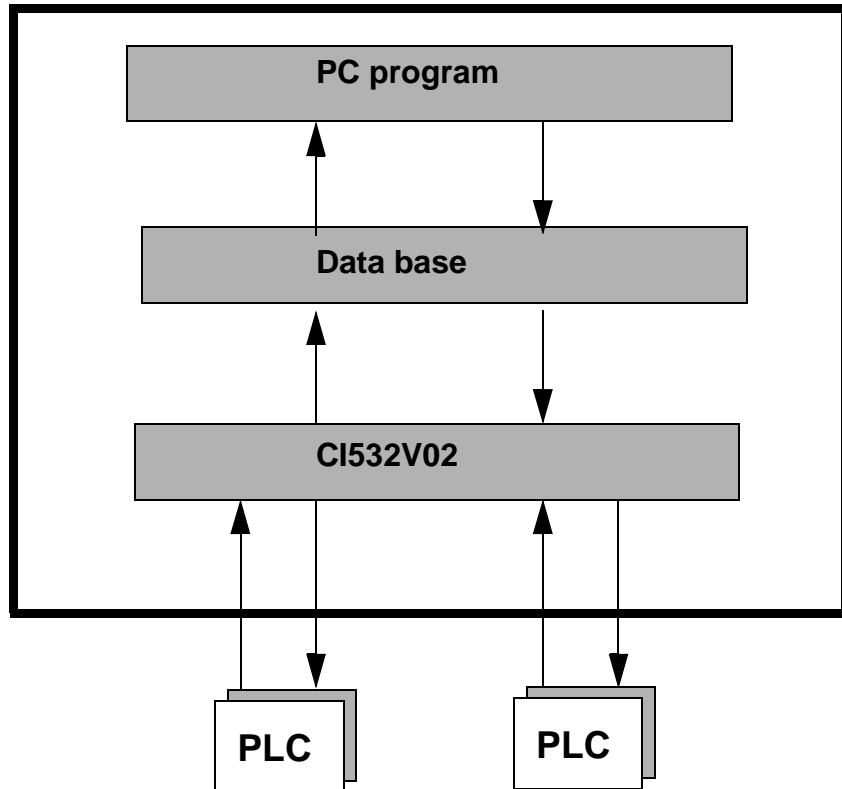

Figure 1-4. Overview of MVI-MODBUS in AC 100

The CI532V02 submodule is installed in the central subrack of the AC 110. The CI532V02 submodule is equipped with two independent, asynchronous communication ports for MVI-MODBUS communication. You can configure the ports as either master or slave on the MVI-MODBUS link. The setup of each port is individually defined by a number of MVI specific data base elements (see Section 3.6, Configuration of MVI-MODBUS Application data base and PC program).

Each port forms a local control network within the ABB Master system with the network numbers 1 to 9. In master mode, CI532V02 can handle up to eight slaves. Since every PLC on the MVI-MODBUS bus is part of an ABB Master control network, each PLC must have a unique node number, 1 to 99, within the controller concerned.